

RoHS Compliant

SYMBOL	REV.	REVISION	APPROVAL	DATE

SPECIFICATIONS

1. ELECTRICAL CHARACTERISTICS:
 - 1-1. RATING: DC 16V 3A
 - 1-2. CONTACT RESISTANCE: 30mΩ MAX(INITIAL)
 - 1-3. DIELECTRIC WITHSTANDING VOLT TAGE: 500V AC FOR ONE MINUTE
 - 1-4. INSULATION RESISTANCE: 100MΩ MIN, MEASURED BY 500V DC
2. LIFE TEST:
 - 2-1. Electronics Life Test 6,000 cycles.
 - 2-2. Mechanical Life Test 30,000 cycles.

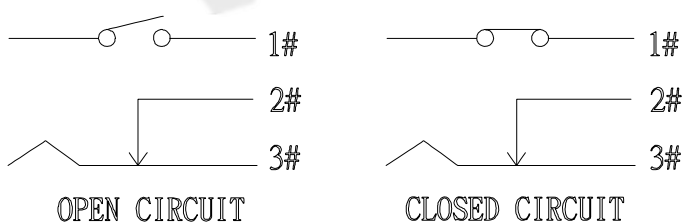
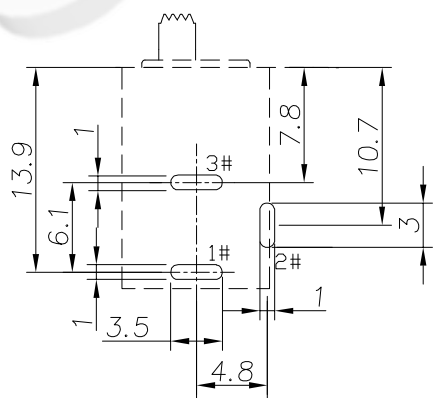
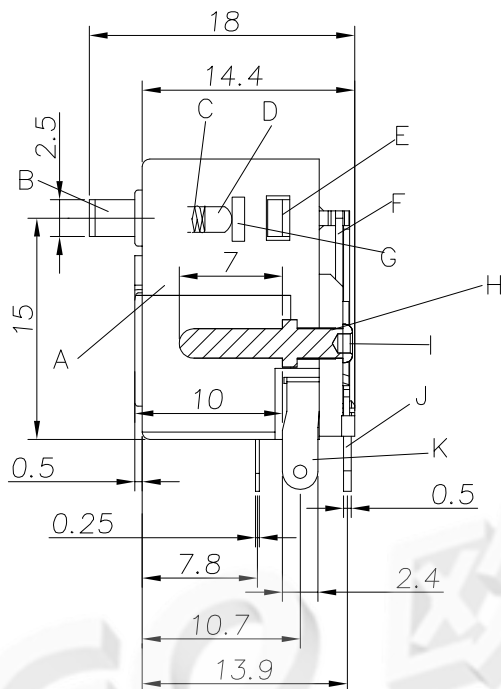
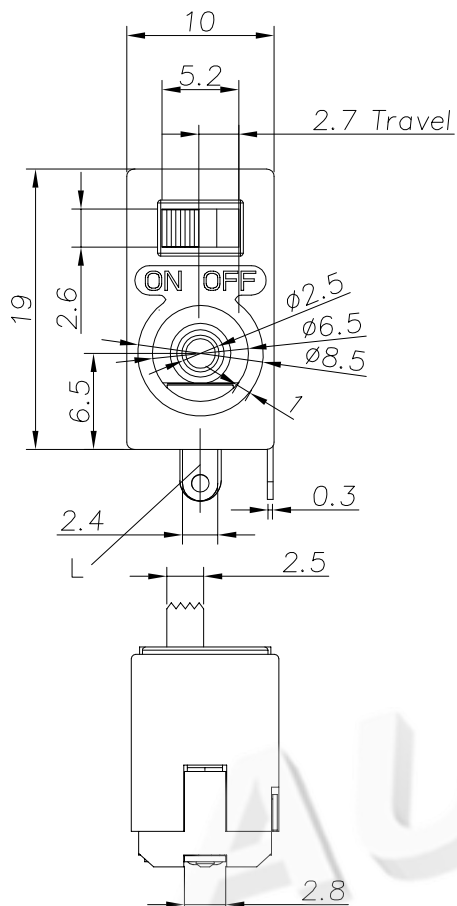

SCHEMATIC

No.	DESCRIPTION	MATERIAL	PLATING
A	HOUSING	PA66 94V-0	BLACK
B	KNOB	PA66 94V-0	WHITE
C	SPRING	STAINLESS STEEL	NATURAL
D	BEAD	SUS	NATURAL
E	COVER 1	PA66 94V-0	BLACK
F	TERMINAL 1	C2680	Ag Plated
G	CONTACT PIECE	C2680	Ag Plated
H	COVER 2	PA66 94V-0	BLACK
I	PIN	BARSS	Ni Plated
J	TERMINAL 2	C2680	Ag Plated
K	TERMINAL 3	C2680	Ag Plated
L	TERMINAL 4	SUS	Ag Plated

AUGO ELECTRONICS CO.,LTD.

COPYRIGHT RESERVED, PLEASE DO NOT COPY.

PART NAME		JACK & SWITCH SERIES		DRAWING		DWG.No.	
PART NO.		JS-11-D65-25		CHECK		REV.	
UNIT: mm		TOLERANCE UNLESS OTHERWISE SPECIFIED		ANGLE		DATE	
		>10 ±0.4 <10 ±0.25		±2°		SCALE	
				APPROVAL		PAGE	
				SCALE		1 OF 1	